

# Central Brass

## COMPANY

A Division of Pioneer Industries, Inc.

## Installation Guide

### Two Handle Tub Filler, Shower & Tub & Shower Set:

#### 6" Centers, I.P. Unions, Compression Stems, Replaceable Seats

- 6056 Series
- 6086 Series
- 6076 Series
- 6266 Series

#### 8" Centers, Direct Sweat, Compression Stems, Replaceable Seats

- 0805 Series
- 0808 Series
- 0826 Series
- 0897 Series

#### 8" Centers, Direct Sweat, Ceramic Stems

- 80805 Series
- 80808 Series
- 80826 Series
- 80897 Series

#### 8" Centers, I.P. Unions, Compression Stems, Replaceable Seats

- 0905 Series
- 0908 Series
- 0926 Series
- 0997 Series

#### 8" Centers, I.P. Unions, Ceramic Stems

- 80905 Series
- 80908 Series
- 80926 Series
- 80997 Series

### This product meets the following standards:

- ASME A112.18.1
- ANSI A117.1
- ADA COMPLIANT(Only Products With L3 Handles)



## Thank You For Choosing Central Brass Products

Thank you for purchasing this quality product.

Central Brass products are rigorously tested to provide long service under normal conditions. Prior to installation, familiarize yourself with this products diagram.

Make sure that you have all of the illustrated parts for your Central Brass product before installation.

## Care Instructions

Central Brass products are designed and engineered under strict quality standards. The Central Brass Collection of PVD finishes feature a strong and durable surface that will keep your fixture looking exquisite for a lifetime.

To ensure the beautiful appearance of your Central Brass product, please adhere to the following simple care instructions:

- Use clean water to clean the surface of the faucet and dry with a 100% cotton cloth.
- You may also use any non-abrasive wax, along with a soft cotton cloth to brighten the surface and provide future protection of the finish.
- Do not use detergents, harsh cleaners, abrasive cleaners, cloths, and cleaning agents.

Note:- This is not a pressure balance valve. It may not meet local code.

## CENTRAL BRASS LIMITED WARRANTY

The Central Brass Company provides to the original consumer the following warranties for Genuine Central Brass manufactured products and components used in commercial or residential applications.

Central Brass Company will replace, free of charge, to the original consumer purchaser, any and all parts that prove defective under normal installation, use, and service. This warranty does not cover damage or defects due to normal wear and tear, misuse, abuse, accident, or improper installation. Replacement parts can be obtained from your local dealer or directly from Central Brass Company. Central Brass Company recommends using a certified plumber for all Tub & Shower Set Installation and repair. Dated proof of purchase must accompany all warranty claims.

### **FAUCET WARRANTY**

The Faucet, defined as any metal cast, forged, stamped or formed portion of the product, not including moving parts or other components covered under other Central Brass warranties, is warranted against manufacturing defects for the life of the product.

### **CARTRIDGE WARRANTY**

Genuine Central Brass cartridges incorporated in Central Brass products are warranted against manufacturing defects for a period of five (5) years from the date of purchase.

### **SENSOR FAUCETS**

The mechanics of the Central Brass Sensor Faucets are warranted for five (5) years from the date of installation. The electronics and solenoid are warranted for a period of one (1) year from the date of installation.

### **FINISH WARRANTY - COMMERCIAL**

PVD finishes installed in public or commercial areas are warranted not to corrode, tarnish or discolor for a period of five (5) years from date of purchase.

### **FINISH WARRANTY – RESIDENTIAL**

PVD finishes installed in residential use applications are warranted not to corrode, tarnish or discolor for the life of the product.

## Tab & Shower Set Installation

1. Determine the location of the valve to be installed for new installation. For existing installation look at the installation drawing and ensure there is enough room to install the valve.
2. Install the outlet connections. If the installation is for tub only or shower only use cap to block one of the outlet. Apply teflon tape at threaded connections. Install inlet connections. Hot water supply should be on the left hand side and cold water supply should be on the right hand side.
3. For CXC installation:-Remove stem units, gaskets and built-in transfer valve before soldering. Failure to do so can result in damage to stem units. Cool valve assembly after solder connections are completed before reinstalling stem assemblies and built-in transfer valve.

### 1 Valve Installation

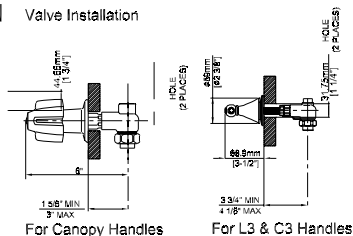

### 2

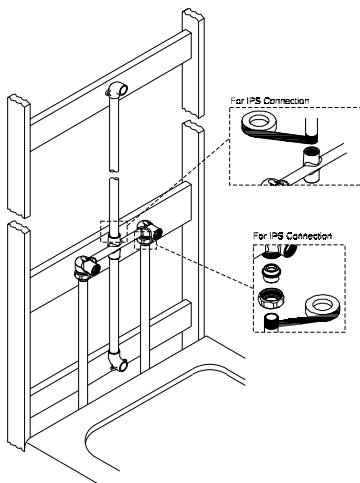

### 3 For CXC Installation

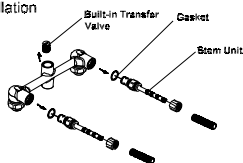

## Tub & Shower Set Installation

### 4. For Slip-Fit Tub Spout Installation:

- (A) The 1/2" nominal copper tube must be cut with a minimum length of 2-1/4" to a maximum length of 2-5/8" from finished tub or wall surface.
- (B) The end of copper tube should be chamfered free of any burrs to prevent cutting or nicking o-ring inside the spout. The outside surface may be sanded free from nicks and scratches.
- (C) Press and twist the spout over copper tube flush with the finished tub or wall surface.
- (D) Tighten the set screw, but do not overtighten.

### 5. For IPS Tub Spout Installation:

- (A) The 1/2" threaded pipe nipple must be kept with a minimum length of 1-1/8" to maximum length of 1-3/8" from finished tub or wall surface.
- (B) Remove octagonal nut inside the spout by using nose plier.
- (C) Apply teflon tape at the threaded connection. Screw tub spout onto the threaded pipe nipple and tighten by strap wrench.

#### 4 1/2" Slip-Fit Installation:

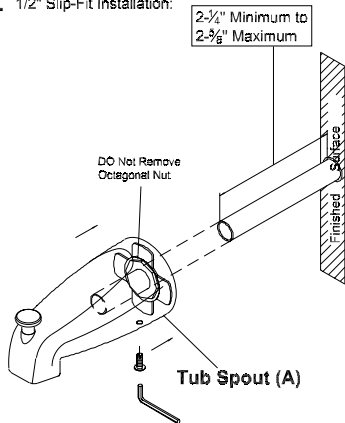

#### 5 1/2" IPS Installation:

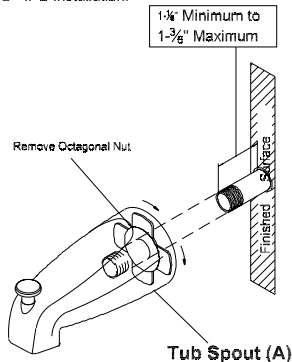

## Tub & Shower Set Installation

- Caution:- To avoid plugging the showerhead spray outlet use teflon tape on the shower arm threads.
6. Use silicon to caulk the back of the shower arm flange(B). Slide the shower arm flange(B) over the shower arm(C). Apply the teflon tape on both threaded ends of shower arm(C) and install the shower arm(C) to the shower elbow. Carefully tighten with a clean strap wrench. Press the shower arm flange(B) against the finished wall. Flush out the system.Thread the showerhead(D) to the shower arm(C).
  7. For L3 and C3 Handles:- Ensure the distance between Center of valve inlets to wall is 2-1/2" Min. to 4" Max. If needed then mark the distance from the end of the replacement brass nipple. Carefully cut the nipple at the outer edge of the step closest to the mark (Fig 10). Carefully cut stem post similarly but at the inner edge of the step. Avoid cutting the spline and threaded area. The cut must be straight and all burs removed. For All Installation:- Thread escutcheon (E) to the valve. Use silicon to calk the back of the escutcheon (E). Install the cold and hot side handles (F). Install the appropriate length screws(G). For L3 and C3 handles place the caps (H).

## 7

# Tub & Shower Set Installation

6

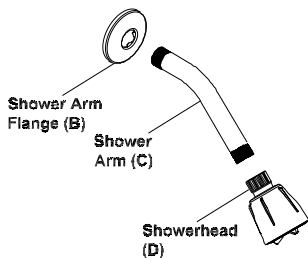

7

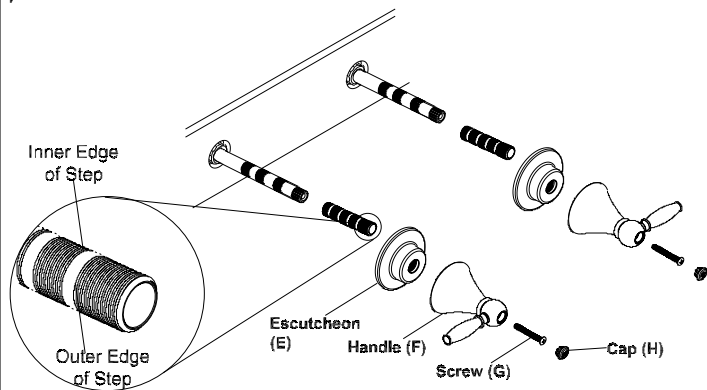

## Maintenance Instruction

### DISASSEMBLY

#### 1 REMOVE HANDLE

1. Turn off water supply
2. Remove the handle screw & handle
3. Unscrew the escutcheon

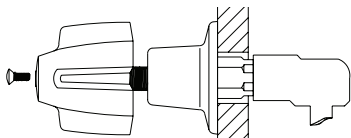

#### 2 REMOVE STEM ASSEMBLY

1. Use socket set.
2. Turn stem to open position
3. Unscrew counterclockwise. Remove stem unit.

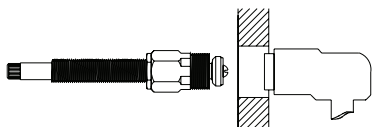

#### 3 REMOVE SEAT

1. Insert 5/16" allen wrench in seat.
2. Turn seat (counterclockwise) to remove.

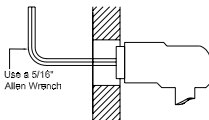

### REPLACEMENT

#### 4 Use Only Central Replacement Parts

**K-3-CT** Compression Stem Kit use for cold & hot sides

**K-351-C** Ceramic Stem Kit Cold

**K-351-H** Ceramic Stem Kit Hot

- If faucet has round handles (G-508) or (80 suffix), use Cold stem assemblies for both cold & hot sides.
- If faucet has lever handles, use one Hot and one Cold stem assemblies

**K-3-CT**

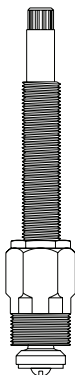

**K-351-C**

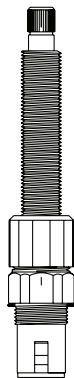

**NOTE:** If replacing compression units with ceramic units make sure PF-263-B seat is removed from body before installing stem units.

For more care information or trouble shooting inquiries about your Central Brass product, please see the contact information on the back page.



# Central Brass

C O M P A N Y

A Division of Pioneer Industries, Inc.

6892 Snowville Road | Brecksville, Ohio 44141  
Telephone: (800) 321-0220 | (216) 883-0220 | Fax: (800) 338-9414  
Hours: M - F, 7:30am to 5:00pm EST  
[www.centralbrass.com](http://www.centralbrass.com)